



**OUTLAND  
TECHNOLOGY  
INC.**

# COLOR ZOOM CAMERA

0010610

## MODEL UWC-500

DIVER, ROV, OR DROP UNDERWATER  
COLOR VIDEO CAMERA

FEB.98

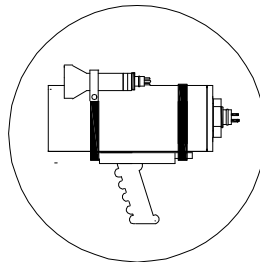
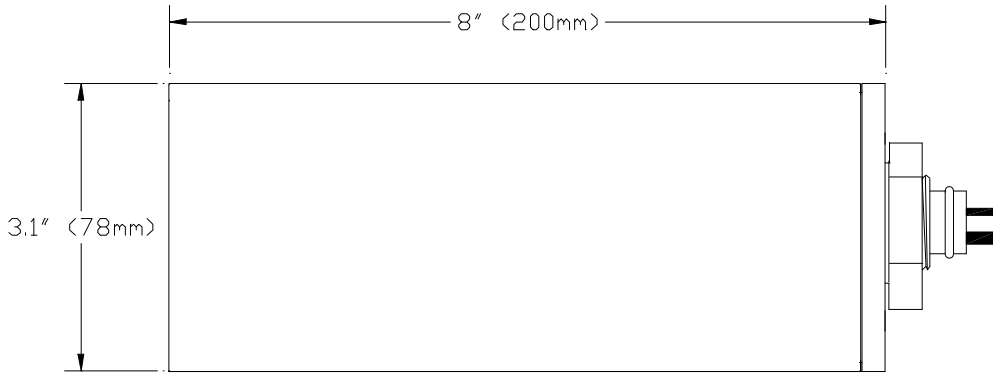

Assembled for Diver operation

**USES INCLUDE: DIVER, ROV, MANIPULATOR ARM, DROP CAMERA, ETC.**

**MECHANICAL:**

- Weight..... 3 lbs. (1.4kg) Dry  
Wet .8 lbs. (.36kg)
- Depth Rating..... 3300 ft. (1000 m)
- Housing....6061-T6 Anodized Aluminum
- Housing port..... Acrylic

**ELECTRICAL:**

- Image Device.....1/3" CCD Sensor  
622 H x 485 V, Pixels
- Sensitivity..... 7 lux  
(object)
- Resolution..... 480 Horz. lines.
- PWR..... (9-30 VDC) @ 400 ma.

**OPTICAL:**

- Lens (12-1).....3.2-38.4mm, f1.8-2.7,  
Auto-Iris Zoom.
- Focus..... Auto or remote,  
macro to Infinity.
- Horz. FOV.....70 to 6.2 degrees.

**CONNECTOR:**

Standard Connector..... XSK-5-BCL  
(Mate is RMK-5-FS)

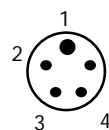

1. Video
2. Ground/Common
3. +12 to 30 VDC
4. Data +
5. Data -

**OPTIONS:**

1. CCIR (PAL) Format.
2. Customer specified connector.
3. 24-1, 380 line, image stabilized lens.
4. Long Line Amplifier.

# MODEL UWS-5010/5020

## COMPLETE UNDERWATER VIDEO SYSTEM

### TECHNICAL SPECIFICATIONS

#### CAMERA, MODEL UWC-500

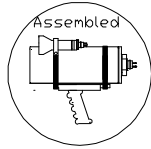
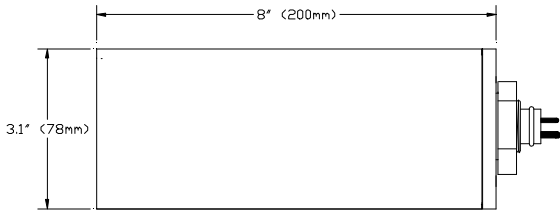

#### MECHANICAL:

- Weight..... 3 lbs.(1.4kg) Dry, .8 lbs.(.36kg) Wet.
- Depth Rating..... 3300 ft. (1000m).
- Housing..... 6061-T6 hard coat anodized Aluminum

#### ELECTRICAL:

- Image Device..... 1/3" CCD sensor (622 x 485 pixels).
- Sensitivity..... 7 lux object.
- Resolution..... 480 TV lines standard.
- Video Out..... 1.2 Vpp, NTSC standard (PAL option).
- Power..... 9-30 VDC @ 400 ma.

#### OPTICAL:

- Lens(12-1)..... 3.2 - 38.4mm, f1.8-2.7, Auto-Iris Zoom.
- Focus..... Automatic or Remote, macro to Infinity.
- Horz. Angle of View..... 70 to 6.2 degrees.

#### LIGHT, MODEL UWL-200

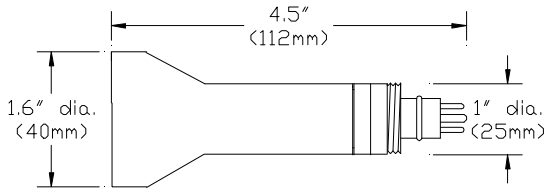

#### MECHANICAL:

- Weight..... 21oz. (.6 kg) Dry, 20 oz.(.48 kg) Wet.
- Depth Rating..... 3300 ft. (1000m).
- Housing..... 17-4 Stainless

#### ELECTRICAL:

- Power..... up to 150 watts
- Color Temp..... 3000k
- Bulb..... Q150/cl/mc std., (75 & 100 Opt.)

#### CABLE, MODEL C-5501

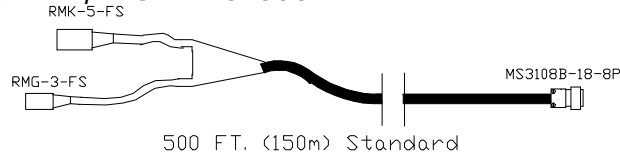

- Conductors..... 3 ea. #18, 4 ea.#20 awg,1 RG-59 Coax
- Length..... 500 ft. (150m) Standard
- Diameter..... .5" (12.5 mm)
- Materials..... Yellow, Polyurethane jacket.
- Interstices..... Water Blocked

#### CONSOLE, MODEL CON-3000

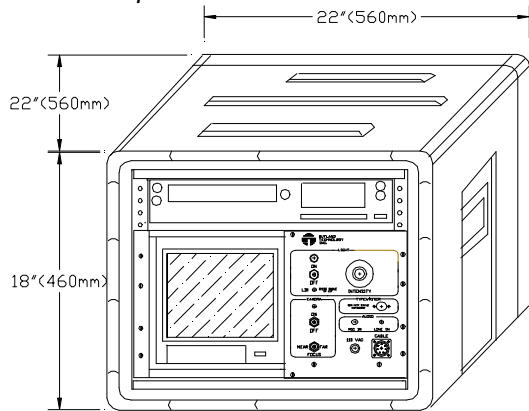

- Weight..... 90 Lbs. (40kg)
- Power..... 110 VAC/60Hz, fused at 5 amperes. (4020, 110/220 VAC 50/60 Hz.)
- Light Control..... Variable control, 0-100%, 0-250 watts.
- Monitor..... 10" Color w/audio.
- Safety..... GFI for main power, LIM to monitor umbilical, Isolation transformer for light.
- Connections..... Front panel connections for umbilical, Audio & Mic.
- VCR..... VHS format (standard)
- Typewriter..... Time/Date, 10 pages of text, digital control of camera from keyboard.

#### OPTIONS:

- |  |  |   |   |
|--|--|---|---|
| <ul style="list-style-type: none"> <li>•Camera,</li> <li>•Light,</li> <li>•Cable,</li> </ul> | <ul style="list-style-type: none"> <li>1. 380 Line resolution. image stablized 24-1.</li> <li>2. Optional connectors</li> <li>3. Long Line Amp for up to 5Kft.</li> <li>1. UWL-100, 250 watt light.</li> <li>1. User Specified cable lengths.</li> </ul> | <ul style="list-style-type: none"> <li>•Recorder,</li> <li>•Booster,</li> </ul> | <ul style="list-style-type: none"> <li>1. S-VHS, 400 line recorder.</li> <li>2. Hi-8mm, 400 line recorder.</li> <li>For cable over 1500 ft. to 3000 ft. Mounts in console.</li> </ul> |
|--|--|---|---|